



# **OPERATOR'S MANUAL**

## **WHEELED WEEDTRIMMER**

- **Assembly**
- **Operation**
  - **Maintenance**
    - **Service and Adjustments**
    - **Storage**
      - **Troubleshooting**

# TABLE OF CONTENTS

Safety Rules .....	2-4	Maintenance .....	10-13
Assembly .....	4	Service and Adjustments .....	14-15
Operation .....	5-9	Storage .....	15-16
Maintenance Schedule .....	10	Troubleshooting .....	17

**⚠ WARNING:** This trimmer is equipped with an internal combustion engine and should not be used on or near any unimproved forest-covered, brush-covered or grass-covered land unless the engine's exhaust system is equipped with a spark arrester meeting applicable local or state laws (if any). If a spark arrester is used, it should be maintained in effective working order by the operator.

In the state of California the above is required by law (Section 4442 of the California Public Resources Code). Other states may have similar laws. Federal laws apply on federal lands. A spark arrester for the muffler is available through your nearest authorized service center/department.



## SAFETY RULES



The operation of any trimmer can result in foreign objects thrown into the eyes, which can result in severe eye damage. Always wear safety glasses or eye shields while operating your trimmer or performing any adjustments or repairs. We recommend a wide vision safety mask over spectacles or standard safety glasses.

### I. GENERAL OPERATION

- Read, understand, and follow all instructions on the machine and in the manual before starting. Be thoroughly familiar with the controls and the proper use of the machine before starting.
- Do not put hands or feet near or under rotating parts.
- Keep all parts of your body away from muffler and spinning line. A hot muffler can cause serious burns.
- Only allow responsible individuals, who are familiar with the instructions, to operate the machine.
- Stay away from breakable objects, such as house windows, auto glass, greenhouses, etc.
- Clear the area of objects such as rocks, toys, wire, bones, sticks, etc., which could be picked up and thrown by the spinning lines.
- Be sure the area is clear of other people before trimming, particularly small children and pets. Stop machine if anyone enters the area.
- Wear appropriate clothing such as a long-sleeved shirt or jacket. Also wear long trousers or slacks. Do not wear shorts.
- Do not wear loose clothing which could get caught in this equipment.
- Do not operate the machine when barefoot or wearing open sandals. Always wear work gloves and sturdy footwear. Leather work shoes or short boots work well for most people. These will protect the operator's ankles and shins from small sticks, splinters, and other debris, and improve traction.
- Do not pull machine backwards unless absolutely necessary. Always look down and behind before and while moving backwards.
- Do not operate the machine without proper guards, plates or other safety protective devices in place.
- See manufacturer's instructions for proper operation and installation of accessories. Only use accessories approved by the manufacturer.
- Never use blades, wire, or flailing devices. This unit is designed for line trimmer use only. Use of other accessories or attachments will increase the risk of injury.

- Stop the rotating trimmer head when crossing gravel drives, walks, or roads. Wait for the cutting lines to stop rotating.
- Stop the engine (motor) whenever you leave the equipment and allow it to cool, before cleaning, repairing or inspecting the unit. Be sure the trimmer head and all moving parts have stopped.
- Operate only in daylight or good artificial light.
- Do not operate the machine while under the influence of alcohol or drugs.
- Never operate machine in wet grass. Always be sure of your footing: keep a firm hold on the handle and walk; never run.
- If the equipment should start to vibrate abnormally, stop the engine (motor) and check immediately for the cause. Vibration is generally a warning of trouble.
- Always wear safety goggles or safety glasses with side shields when operating machine.
- Keep children out of the trimming area and under the watchful care of another responsible adult.
- Be alert and turn machine off if children enter the area.
- Before and while moving backwards, look behind and down for small children.
- Never allow children to operate the machine.
- Use extra care when approaching blind corners, shrubs, trees, or other objects that may obscure vision.

#### IV. SERVICE

- Use extra care in handling gasoline and other fuels. They are flammable and vapors are explosive.
  - Use only an approved container.
  - Never remove gas cap or add fuel with the engine running. Allow engine to cool before refueling. Do not smoke.
  - Never refuel the machine indoors.
  - Never store the machine or fuel container inside where there is an open flame, such as a water heater.
  - Move away from fueling site before starting engine.
- Never run a machine inside a closed area.
- Never make adjustments or repairs with the engine (motor) running. Disconnect the spark plug wire, and keep the wire away from the plug to prevent accidental starting.
- Keep nuts and bolts, especially trimmer head and engine bolts, tight and keep equipment in good condition.
- Never tamper with safety devices. Check their proper operation regularly.
- Keep machine free of grass, leaves, or other debris buildup. Clean oil or fuel spillage. Allow machine to cool before cleaning or storing.
- Stop and inspect the equipment if you strike an object. Repair, if necessary, before restarting.
- Do not change the engine governor setting or overspeed the engine.
- Clean and replace safety and instruction decals as necessary.

## II. SLOPE OPERATION

Slopes are a major factor related to slip and fall accidents which can result in severe injury. All slopes require extra caution. If you feel uneasy on a slope, do not trim it.

### DO:

- Trim across the face of slopes: never up and down. Exercise extreme caution when changing direction on slopes.
- Remove obstacles such as rocks, tree limbs, etc.
- Watch for holes, ruts, or bumps. Tall grass can hide obstacles.

### DO NOT:

- Do not trim near drop-offs, ditches or embankments. The operator could lose footing or balance.
- Do not trim excessively steep slopes.
- Do not trim on wet grass. Reduced footing could cause slipping.

## III. CHILDREN

Tragic accidents can occur if the operator is not alert to the presence of children. Children are often attracted to the machine and the trimming activity. Never assume that children will remain where you last saw them.

**▲**Look for this symbol to point out important safety precautions. It means **CAUTION!!! BECOME ALERT!!! YOUR SAFETY IS INVOLVED.**

**⚠ WARNING:** In order to prevent accidental starting when setting up, transporting, adjusting or making repairs, always disconnect spark plug wire and place wire where it cannot contact spark plug.

**⚠ CAUTION:** Muffler and other engine parts become extremely hot during operation and remain hot after engine has stopped. To avoid severe burns on contact, stay away from these areas.

**⚠ WARNING:** Engine exhaust, some of its constituents, and certain vehicle components contain or emit chemicals known to the State of California to cause cancer and birth defects or other reproductive harm.



## ASSEMBLY

Read these instructions and this manual in its entirety before you attempt to assemble or operate your new trimmer.

**IMPORTANT:** This trimmer is shipped WITHOUT OIL OR GASOLINE in the engine.

Your new trimmer has been assembled at the factory with the exception of those parts left unassembled for shipping purposes. All parts such as nuts, washers, bolts, etc., necessary to complete the assembly have been placed in the parts bag. To ensure safe and proper operation of your trimmer, all parts and hardware you assemble must be tightened securely. Use the correct tools as necessary to ensure proper tightness.

### Loose Parts Packed Separately



Bottle of oil

Trimmer Lines  
(2) Sets



(0.130 dia. x 16.75" long)  
(0.155 dia. x 18.75" long)

### TO REMOVE TRIMMER FROM CARTON

1. Remove loose parts included with trimmer.
2. Cut down two end corners of carton and lay end panel down flat.
3. Remove all packing materials.
4. Roll trimmer out of carton and check carton thoroughly for additional loose parts.

### HOW TO SET UP YOUR TRIMMER TO UNFOLD HANDLE

**IMPORTANT:** Unfold handle carefully so as not to pinch or damage control cables.

1. Loosen handle knobs enough to allow upper handle to be unfolded from the shipping position.
2. Raise upper handle section into place on lower handle and tighten handle knob.
3. Remove handle padding holding trimmer head control bar to upper handle.

**22" MODELS ONLY:** Your trimmer handle can be adjusted for your trimming comfort. Refer to "ADJUST HANDLE" in the Service and Adjustments section of this manual.

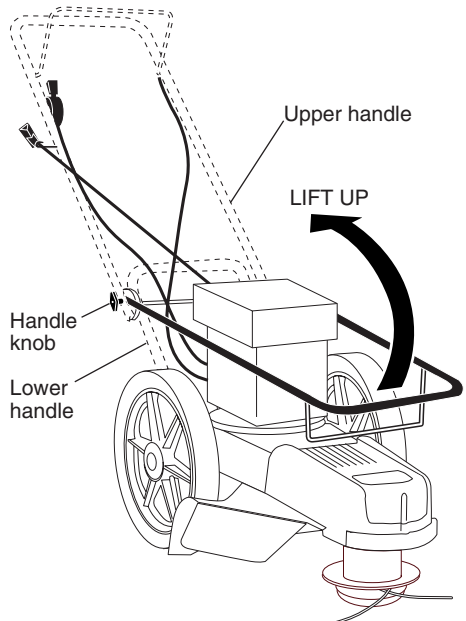

# OPERATION

## KNOW YOUR TRIMMER (TECUMSEH MODELS)

READ THIS OWNER'S MANUAL AND ALL SAFETY RULES BEFORE OPERATING TRIMMER. Compare the illustrations with your trimmer to familiarize yourself with the location of various controls and adjustments. Save this manual for future reference.

These symbols may appear on your trimmer or in literature supplied with the product. Learn and understand their meaning.

**⚠ WARNING**  
**AVOID SERIOUS INJURY OR DEATH**

 READ AND FOLLOW OWNER'S MANUAL.  
LEA Y SIGA EL MANUAL DEL PROPIETARIO.

 DO NOT OPERATE WHEN CHILDREN OR OTHERS ARE AROUND. REMOVE OBJECTS THAT COULD BE THROWN BY THE CUTTING LINES.

 DO NOT SERVICE OR ADJUST CUTTING HEAD OR OTHER MOVING PARTS UNLESS ENGINE IS STOPPED AND SPARK PLUG WIRE IS DISCONNECTED.

 WEAR SAFETY APPROVED EYE PROTECTION WHEN OPERATING.

 GO ACROSS SLOPES NOT UP AND DOWN.

- KEEP SAFETY DEVICES, SUCH AS GUARDS AND DEFLECTORS, IN PLACE AND OPERATING.
- LOOK DOWN AND BEHIND BEFORE AND WHILE MOVING BACKWARDS.



CAUTION



STOP  
ENGINE OFF



FAST



SLOW



FUEL



OIL

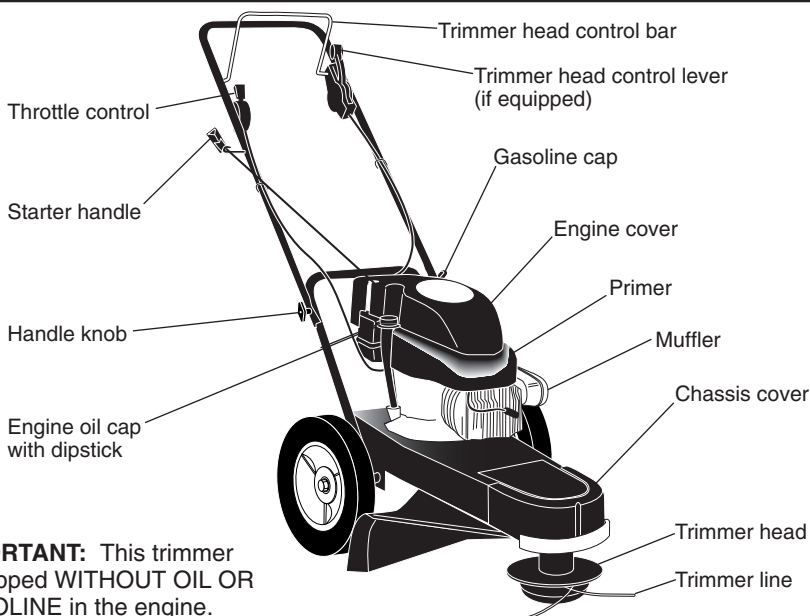

**IMPORTANT:** This trimmer is shipped WITHOUT OIL OR GASOLINE in the engine.

**Trimmer head control bar** - must be held down to the handle to engage trimmer head. Release to stop the trimmer head.

**Primer** - pumps additional fuel from the carburetor to the cylinder for use when starting a cold engine.

**Throttle control** - used for starting and stopping the engine and allows you to select either fast or slow engine speed.

**Starter handle** - used for starting engine.

**Trimmer head control lever (if equipped)**

5 - used to engage trimmer head.

# KNOW YOUR TRIMMER (BRIGGS & STRATTON MODELS)

READ THIS OWNER'S MANUAL AND ALL SAFETY RULES BEFORE OPERATING TRIMMER. Compare the illustrations with your trimmer to familiarize yourself with the location of various controls and adjustments. Save this manual for future reference.

These symbols may appear on your trimmer or in literature supplied with the product. Learn and understand their meaning.



FAST



SLOW



CAUTION



ENGINE OFF



FUEL



OIL

## WARNING

## AVOID SERIOUS INJURY OR DEATH



READ AND FOLLOW OWNER'S MANUAL. LEA Y SIGA EL MANUAL DEL PROPIETARIO.



DO NOT OPERATE WHEN CHILDREN OR OTHERS ARE AROUND. REMOVE OBJECTS THAT COULD BE THROWN BY THE CUTTING LINES.



GO ACROSS SLOPES NOT UP AND DOWN.



DO NOT SERVICE OR ADJUST CUTTING HEAD OR OTHER MOVING PARTS UNLESS ENGINE IS STOPPED AND SPARK PLUG WIRE IS DISCONNECTED.



WEAR SAFETY APPROVED EYE PROTECTION WHEN OPERATING.

- LOOK DOWN AND BEHIND BEFORE AND WHILE MOVING BACKWARDS.

- KEEP SAFETY DEVICES, SUCH AS GUARDS AND DEFLECTORS, IN PLACE AND OPERATING.

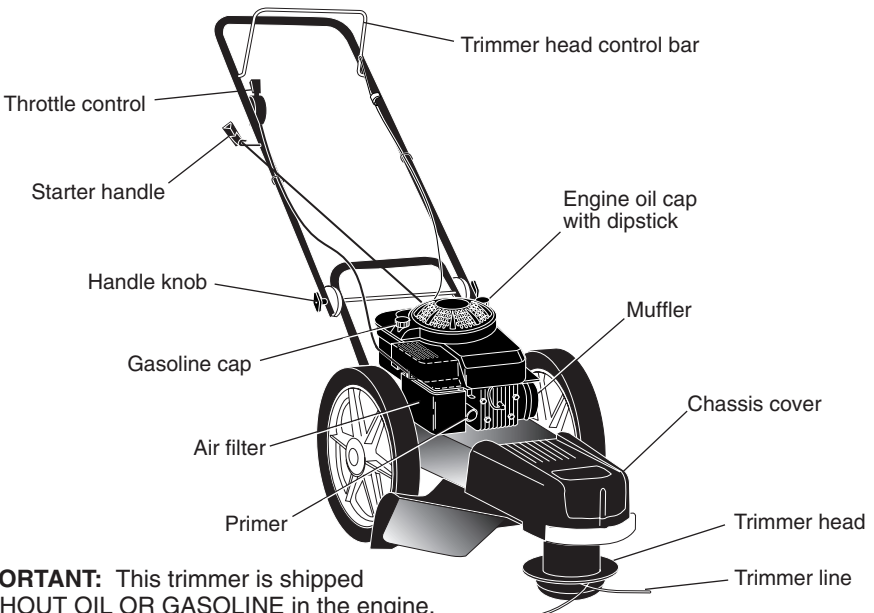

**IMPORTANT:** This trimmer is shipped WITHOUT OIL OR GASOLINE in the engine.

**Trimmer head control bar** - must be held down to the handle to engage trimmer head. Release to stop the trimmer head.

**Primer** - pumps additional fuel from the carburetor to the cylinder for use when starting a cold engine.

**Throttle control** - used for starting and stopping the engine and allows you to select either FAST or SLOW engine speed.

**Starter handle** - used for starting the engine.



The operation of any trimmer can result in foreign objects thrown into the eyes, which can result in severe eye damage. Always wear safety glasses or eye shields while operating your trimmer or performing any adjustments or repairs. We recommend a wide vision safety mask over spectacles or standard safety glasses.

## HOW TO USE YOUR TRIMMER ENGINE SPEED

The engine speed is controlled by a throttle located on the side of the upper handle. Fast position is for starting and normal trimming. Slow is for light trimming and fuel economy. Stop is for stopping the engine.

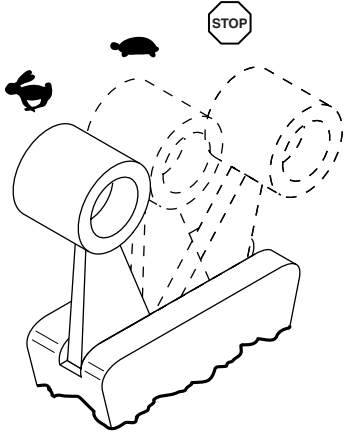

## TRIMMER HEAD DRIVE CONTROL

Your trimmer is equipped with a trimmer head drive control bar and lever (if equipped) which require the operator to be positioned behind the trimmer handle to operate the trimmer.

- Trimmer head rotation is controlled by holding the trimmer head control bar down to the handle. If equipped with a lever, push the drive control lever forward until it clicks; then release the lever.
- Trimmer head rotation will stop when the control bar is released.

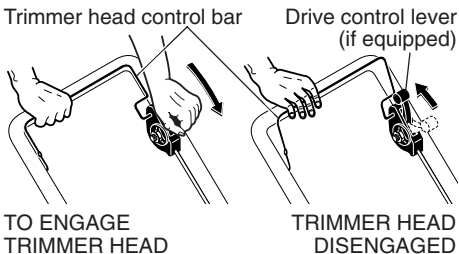

TO ENGAGE TRIMMER HEAD

TRIMMER HEAD DISENGAGED

## TO ADJUST TRIMMING HEIGHT (IF EQUIPPED)

**CAUTION:** Stop the engine and wait for all moving parts to stop. Disconnect spark plug wire from spark plug and place wire where it cannot come in contact with plug.

The height of cut can be set to six (6) different positions ranging from 1-1/2 inches to 3 inches. Recommended cutting height for the average yard is 2 inches.

1. To adjust trimming height, push in the locking plate tab and move trimmer head up or down to desired position.
2. Release tab and be sure head is locked into one of the six (6) height positions.

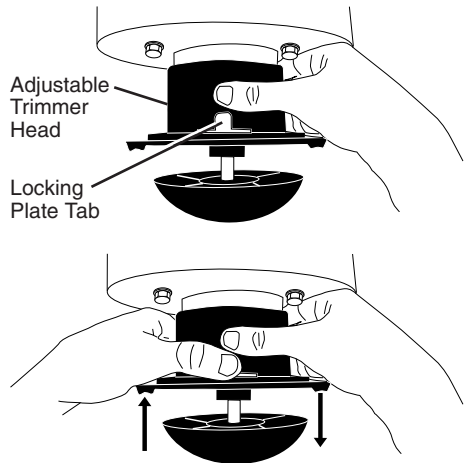

## BEFORE STARTING ENGINE ADD OIL

Your trimmer is shipped without oil in the engine. For type and grade of oil to use, see the engine maintenance section in your engine manual.

**CAUTION:** DO NOT overfill engine with oil, or it will smoke on startup.

1. Be sure trimmer is level and area around oil fill is clean.
2. Remove oil dipstick from oil fill spout. Make sure that rim of spout is clean.

3. You receive a container of oil with the unit. Slowly pour 3/4 (15 oz.) of the oil from the container down the oil fill spout into the engine.
4. Wait one minute to allow oil to settle. Insert and tighten dipstick, then remove it to check oil level.
5. Continue adding small amounts of oil and rechecking the dipstick until it reads full. **DO NOT** overfill, or engine will smoke on startup.
6. Always be sure to retighten oil dipstick before starting engine.
  - Check oil level before each use. Add oil if needed. Fill to full line on dipstick.
  - Change the oil after every 25 hours of operation or each season. You may need to change the oil more often under dusty, dirty conditions.

## ADD GASOLINE

- Fill fuel tank to bottom of gas tank filler neck. Do not overfill. Use fresh, clean, regular unleaded gasoline with a minimum of 87 octane. Do not mix oil with gasoline. Purchase fuel in quantities that can be used within 30 days to assure fuel freshness.

**⚠ CAUTION:** Wipe off any spilled oil or fuel. Do not store, spill or use gasoline near an open flame.

**⚠ CAUTION:** Alcohol blended fuels (called gasohol or using ethanol or methanol) can attract moisture which leads to separation and formation of acids during storage. Acidic gas can damage the fuel system of an engine while in storage. To avoid engine problems, the fuel system should be emptied before storage of 30 days or longer. Empty the gas tank, start the engine and let it run until the fuel lines and carburetor are empty. Use fresh fuel next season. See Storage Instructions for additional information. Never use engine or carburetor cleaner products in the fuel tank or permanent damage may occur.

## TO START ENGINE

1. To start a cold engine, push primer three (3) times before trying to start. Use a firm push. This step is not usually necessary when starting an engine which has already run for a few minutes.
2. Move throttle control lever to fast position.
3. Hold upper handle firmly and pull starter handle quickly. Do not allow starter rope to snap back.

## TO STOP ENGINE

- To stop engine, move throttle control lever to stop position.

**NOTE:** In cooler weather it may be necessary to repeat priming steps. In warmer weather overpriming may cause flooding and engine will not start. If you do flood engine, wait a few minutes before attempting to start and do not repeat priming steps.

### TECUMSEH MODELS:

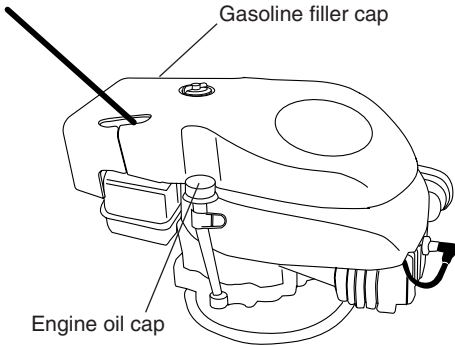

### BRIGGS & STRATTON MODELS:

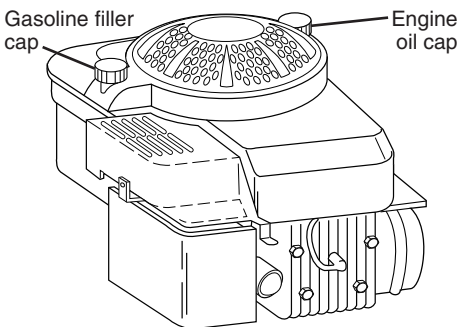



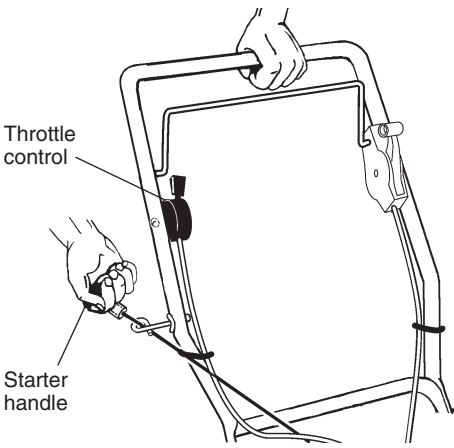

### TRIMMING TIPS

- Set the throttle control in the fast position. If the weeds or grass are tall and thick, operate the trimmer at a slower walking speed.

- Frequently clean the underside of the trimmer to remove any grass build up. Keep top of engine around starter clear and clean of grass clippings and chaff. This will help engine air flow and extend engine life. See "TO REMOVE ENGINE COVER" in the Maintenance section of this manual.
- For best results and longer lasting line, use the ends of the line to do the cutting. This is easily done by moving slowly through very thick and heavy weeds.
- Use the left side of trimmer when trimming along fences, walls, flowerbeds and other such objects.
- If trimmer lines become too short, it will take longer to complete the job. If trimmer lines are worn to less than half their original length, they should be replaced. See "TO REPLACE TRIMMER LINE" in the Maintenance section of this manual.
- Trimmer head contact with concrete, asphalt or other hard surfaces may cause premature wear of the ball on bottom of trimmer head.

# MAINTENANCE

## MAINTENANCE SCHEDULE

FILL IN DATES  
AS YOU COMPLETE  
REGULAR SERVICE

BEFORE EACH USE  
AFTER EACH USE  
EVERY 10 HOURS  
EVERY 25 HOURS  
OR EVERY SEASON  
EVERY 100 HOURS  
BEFORE STORAGE

SERVICE  
DATES

T R I M M E R	Check for Loose Fasteners	✓							✓			
	Clean Trimmer		✓						✓			
	Clean Under Engine Cover	✓ <sub>2</sub>							✓			
	Check Drive Belt / Pulleys				✓							
	Check / Replace Trimmer Lines	✓ <sub>3</sub>										
E N G I N E	Check Engine Oil Level	✓										
	Change Engine Oil				✓ <sub>1,2</sub>							
	Clean Air Filter				✓ <sub>2</sub>							
	Inspect Muffler				✓							
	Clean or Replace Spark Plug				✓							
	Replace Air Filter Paper Cartridge							✓ <sub>2</sub>				

1 - Change more often when operating under a heavy load or in high ambient temperatures.

2 - Service more often when operating in dirty or dusty conditions.

3 - Replace trimmer lines when they have worn to half their original length.

### GENERAL RECOMMENDATIONS

The warranty on this trimmer does not cover items that have been subjected to operator abuse or negligence. To receive full value from the warranty, operator must maintain trimmer as instructed in this manual.

Some adjustments will need to be made periodically to properly maintain your unit. All adjustments in the Service and Adjustments section of this manual should be checked at least once each season.

- Once a year, replace the spark plug and replace air filter element. A new spark plug and clean/new air filter element assure proper air-fuel mixture and help your engine run better and last longer.
- Follow the maintenance schedule in this manual.

### BEFORE EACH USE

1. Check engine oil level.
2. Check for loose fasteners.
3. Clean under engine cover.

### LUBRICATION

To prolong the useful life of your trimmer, change engine oil as recommended in this section of Operator's Manual.

**IMPORTANT:** Do not oil or grease plastic wheel bearings. Viscous lubricants will attract dust and dirt that will shorten the life of the self-lubricating bearings. If you feel they must be lubricated, use only a dry, powdered graphite type lubricant sparingly.

## TRIMMER

Always observe safety rules when performing any maintenance.

## TIRES

- Keep tires free of gasoline, oil, or insect control chemicals which can harm rubber.
- Avoid stumps, stones, deep ruts, sharp objects and other hazards that may cause tire damage.

## TRIMMER LINE

For best results, replace trimmer lines when they have worn to half their original length.

**20" models use .130 inch diameter trimmer line. Cut new trimmer line length to 16-3/4 inches.**

**22" models use .155 inch diameter trimmer line. Cut new trimmer line length to 18-3/4 inches.**

After new line is installed on trimmer head, check all lines so they do not vary more than one (1) inch in length. This is important to make sure the trimmer head is balanced and will not vibrate abnormally.

**⚠WARNING:** Use only the specified trimmer line. Do not use other materials such as wire, string, rope, etc. Wire can break off during trimming and become a dangerous missile that can cause serious injury.

### TO CUT LINE TO PROPER LENGTH

**NOTE:** Trimmer line pre-cut to proper length is available for this unit; see the Repair Parts section of this manual.

If trimmer line is purchased in bulk, it must be cut to length before using. Use the built-in length gauge as follows:

1. From front of trimmer, place the end of spooled trimmer line at the mark on the side of the debris shield as shown.
2. Wrap trimmer line around front of chassis cover to other side and cut at the mark (for your unit's width of cut).

### 20" MODELS

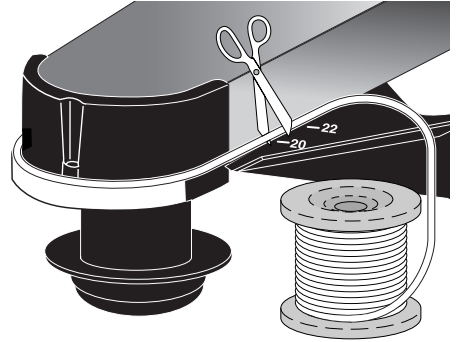
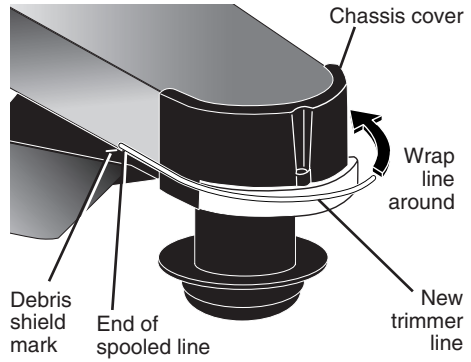

### 22" MODELS

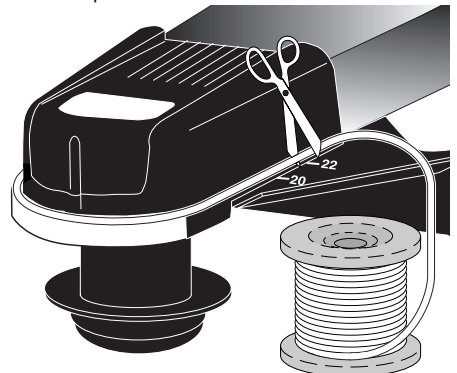
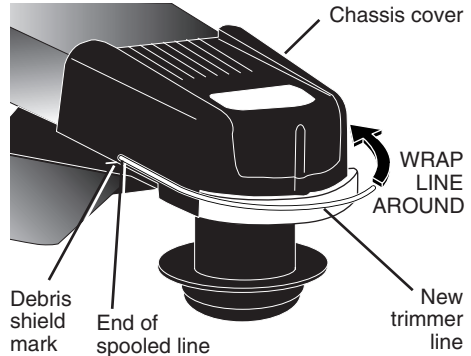

## TO REPLACE TRIMMER LINE

1. Disconnect spark plug wire from spark plug and place wire where it cannot come in contact with spark plug.
2. Remove worn trimmer line from line carrier plate.
3. Fold new, cut to length, trimmer line in half and insert folded end through carrier plate opening to back side of retainer clip.
4. With folded end of line at back side of retainer clip, pull line outward until line is fully seated under retainer clip.
5. Repeat on other side of carrier plate.
6. Check all lines to be sure they are the same length.
7. Reconnect spark plug wire to spark plug.

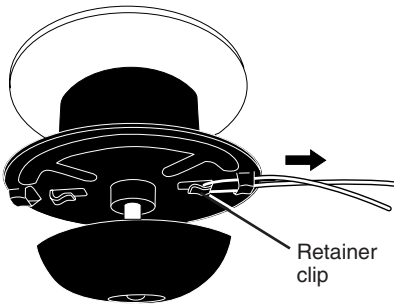
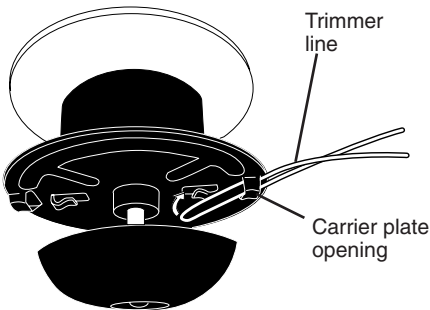

## ENGINE

Read the maintenance section of your engine manual.

### LUBRICATION

#### TO CHANGE ENGINE OIL

Change the oil after every 25 hours of operation or at least once a year if the trimmer is not used for 25 hours in one year. Refer to engine manual.

**NOTE:** Before tipping trimmer to drain oil, drain fuel tank by running engine until fuel tank is empty.

1. Disconnect spark plug wire from spark plug and place wire where it cannot come in contact with spark plug.
2. Remove engine oil cap; lay aside on a clean surface.
3. Tip trimmer on its side as shown and drain oil into a suitable container. Rock trimmer back and forth to remove any oil trapped inside of engine.
4. Wipe off any spilled oil on trimmer or on side of engine.
5. Fill engine with oil (See "ADD OIL" in the Operation section of this manual).
6. Replace engine oil cap.
7. Reconnect spark plug wire to spark plug.

#### TECUMSEH MODELS

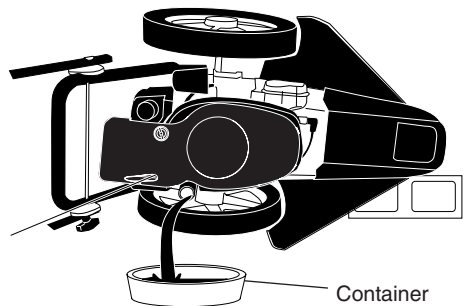

#### BRIGGS & STRATTON MODELS

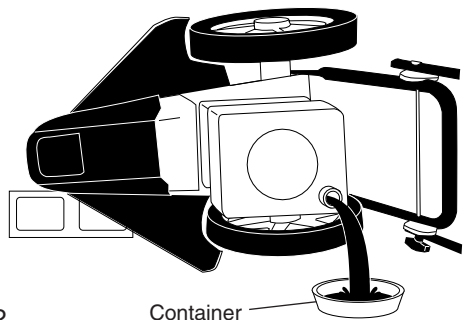

## AIR FILTER

Your engine will not run properly and may be damaged by using a dirty air filter. Replace the air filter every 100 hours of operation or every season, whichever occurs first. Service air cleaner more often under dusty conditions. Do not wash air filter. Refer to engine manual.

## MUFFLER

Inspect and replace corroded muffler as it could create a fire hazard and/or damage.

## SPARK PLUG

Change your spark plug each year to make your engine start easier and run better. Set spark plug gap according to engine manual specifications.

## CLEANING

**IMPORTANT:** For best performance, keep trimmer free of built-up grass and trash. Clean the underside of your trimmer after each use.

**CAUTION:** Disconnect spark plug wire from spark plug and place wire where it cannot come in contact with the spark plug.

- Turn trimmer on its side. Make sure air filter and carburetor are up. Clean the underside of your trimmer by scraping to remove build-up of grass and trash.
- Clean engine often to keep trash from accumulating. A clogged engine runs hotter and shortens engine life.
- Keep finished surfaces and wheels free of all gasoline, oil, etc.
- We do not recommend using a garden hose to clean trimmer unless the electrical system, muffler, air filter and carburetor are covered to keep water out. Water in engine can result in shortened engine life.

## CLEAN UNDER ENGINE COVER (TECUMSEH MODELS ONLY)

Clean under engine cover before each use, or more frequently in heavy cutting or dirty conditions. Engine cover screen and engine air intake screen must be kept free of dirt and chaff to prevent engine damage from overheating.

Be sure engine is cool before cleaning.

1. Unscrew knob on top of cover.
2. Lift cover up and away from engine.
3. Clean cover and cover screen thoroughly.
4. Clean top of engine and air intake screen.
5. Replace engine cover and tighten knob securely. Be sure the front tabs of engine cover are located in the slots in engine housing.

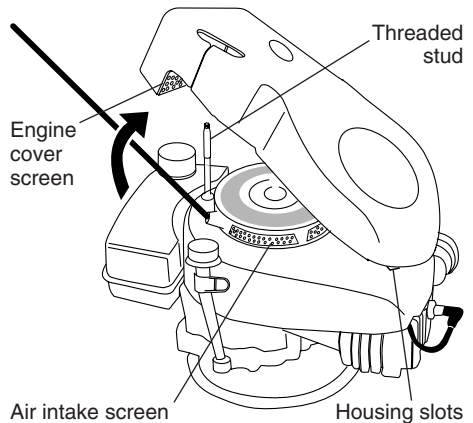
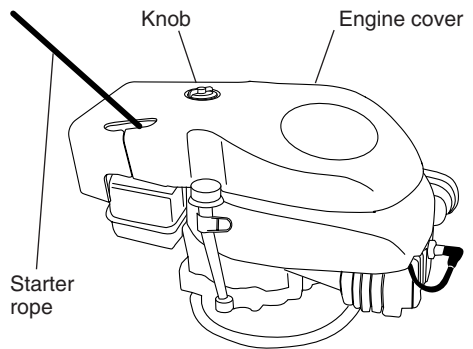

# SERVICE AND ADJUSTMENTS

**⚠ CAUTION:** Before performing any service and adjustments:

1. Stop engine.
2. Make sure the rotating lines and all moving parts have completely stopped.
3. Disconnect spark plug wire from spark plug and place where it cannot come in contact with plug.

## TRIMMER

### TO ADJUST TRIMMING HEIGHT

See "TO ADJUST TRIMMING HEIGHT" in the Operation section of this manual.

### TO ADJUST HANDLE (IF EQUIPPED)

The upper handle may be adjusted to different height positions.

- Loosen handle knob only enough to allow the upper handle to pivot to the desired position.
- Tighten handle knob securely.

**NOTE:** The handle knob and bolt may be reversed for left handed operation.

Upper handle

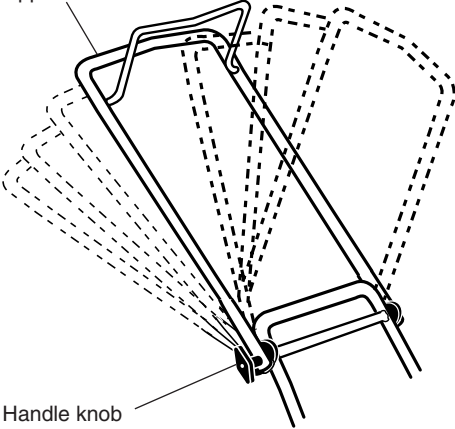

Handle knob

### TO REMOVE / REPLACE TRIMMER HEAD DRIVE BELT

1. Remove screw at front of chassis cover.
2. Lift cover up and away from trimmer.

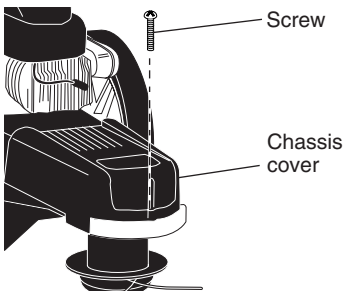

Screw

Chassis cover

3. Remove the two (2) screws on sides of trimmer securing the debris shield.
4. Turn trimmer on its side with carburetor and fuel cap up.
5. Remove the two (2) screws on underside of trimmer securing the debris shield.
6. Slide the debris shield rearward and remove.
7. Remove belt from engine pulley on crankshaft.

### TECUMSEH MODELS

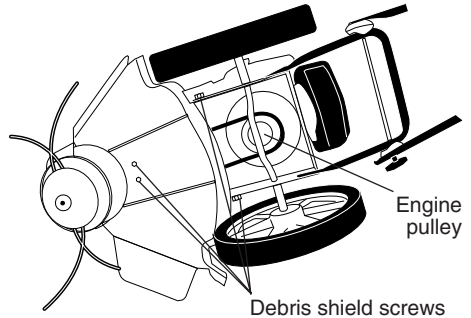

Engine pulley

Debris shield screws

### BRIGGS & STRATTON MODELS

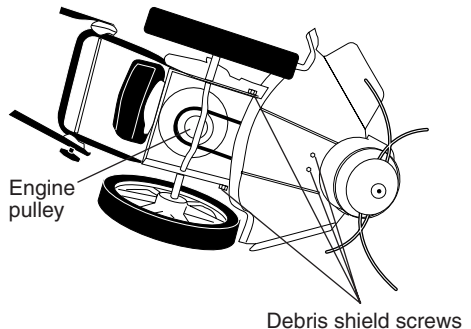

Engine pulley

Debris shield screws

8. Remove belt from trimmer head pulley.
9. Note the position of the control cable and idler return spring, then remove idler assembly from chassis and remove belt and idler from trimmer.
10. Remove belt from idler assembly by removing bottom belt keeper and idler pulleys.

- Assemble new belt, idler pulleys and bottom belt keeper to idler bracket. Tighten pulley bolts securely.

**NOTE:** Be sure belt is inside top belt keeper on idler assembly.

- Position belt and idler assembly in trimmer, reconnect idler spring and assemble idler to chassis.

- Install belt around trimmer head pulley and engine pulley.
- Replace debris shield and tighten the four (4) screws securely.
- Replace chassis cover and tighten screw securely.

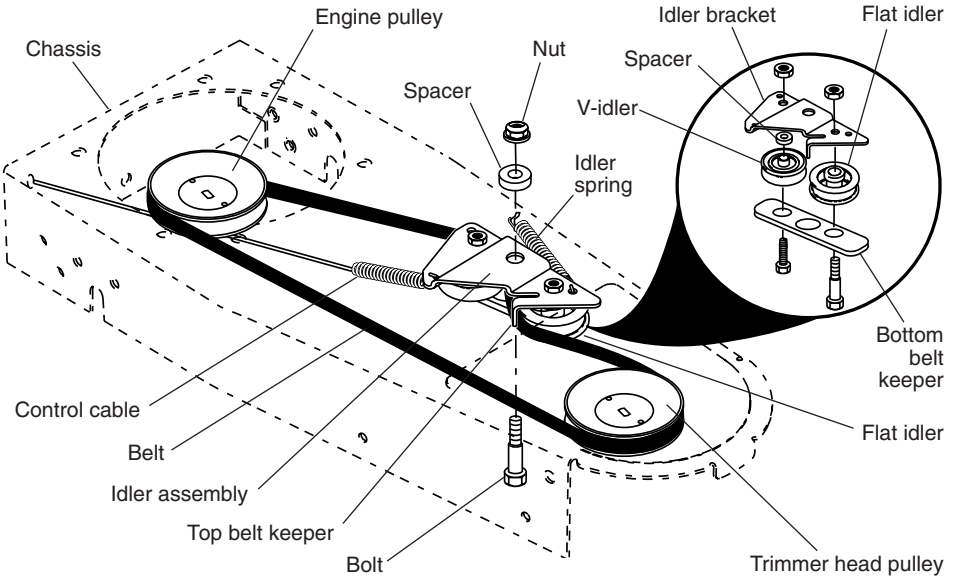

## ENGINE SPEED

Your engine speed has been factory set. Do not attempt to increase engine speed or it may result in personal injury. If you believe that the engine is running too fast or too slow, take your unit to a qualified service center for repair and/or adjustment.

## CARBURETOR

Your carburetor has a nonadjustable fixed main jet for mixture control. If your engine does not operate properly due to suspected carburetor problems, take your

unit to a qualified service center for repair and/or adjustment.

**IMPORTANT:** Never tamper with the engine governor, which is factory set for proper engine speed. Overspeeding the engine above the factory high speed setting can be dangerous. If you think the engine-governed high speed needs adjusting, take your unit to a qualified service center, which has proper equipment and experience to make any necessary adjustments.

## STORAGE

Immediately prepare your trimmer for storage at the end of the season or if the unit will not be used for 30 days or more.

### TRIMMER

When trimmer is to be stored for a period of time, clean it thoroughly, remove all dirt, grease, leaves, etc. Store in a clean, dry area.

- Clean entire trimmer (See "CLEANING" in the Maintenance section of this manual).
- Lubricate as shown in the Maintenance section of this manual.
- Be sure that all nuts, bolts, screws, and pins are securely fastened. Inspect moving parts for damage, breakage and wear. Replace if necessary.

4. Touch up all rusted or chipped paint surfaces; sand lightly before painting.

## HANDLE

You can fold your trimmer handle for storage.

- Loosen handle knob enough to allow upper handle to be folded forward.

**IMPORTANT:** When folding the handle for storage or transportation, be sure to fold the handle as shown or you may damage the control cables.

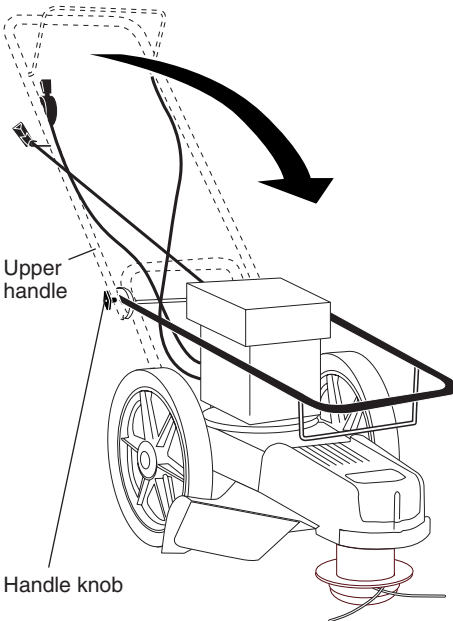

## ENGINE

### FUEL SYSTEM

**IMPORTANT:** It is important to prevent gum deposits from forming in essential fuel system parts such as carburetor, fuel filter, fuel hose or tank during storage. Also, alcohol blended fuels (called gasohol or using ethanol or methanol) can attract moisture which leads to separation and formation of acids during storage. Acidic gas can damage the fuel system of an engine while in storage.

1. Drain the fuel tank.

2. Start the engine and let it run until the fuel lines and carburetor are empty.

- Never use engine or carburetor cleaner products in the fuel tank or permanent damage may occur.
- Use fresh fuel next season.

**NOTE:** Fuel stabilizer is an acceptable alternative in minimizing the formation of fuel gum deposits during storage. Add stabilizer to gasoline in fuel tank or storage container. Always follow the mix ratio found on stabilizer container. Run engine at least 10 minutes after adding stabilizer to allow the stabilizer to reach the carburetor. Do not drain the gas tank and carburetor if using fuel stabilizer.

### ENGINE OIL

Drain oil (with engine warm) and replace with clean engine oil. (See "ENGINE" in the Maintenance section of this manual).

### CYLINDER

1. Remove spark plug.
2. Pour one ounce (29 ml) of oil through spark plug hole into cylinder.
3. Pull starter handle slowly a few times to distribute oil.
4. Replace with new spark plug.

### OTHER

- Do not store gasoline from one season to another.
- Replace your gasoline can if your can starts to rust. Rust and/or dirt in your gasoline will cause problems.
- If possible, store your unit indoors and cover it to give protection from dust and dirt.
- Cover your unit with a suitable protective cover that does not retain moisture. Do not use plastic. Plastic cannot breathe, which allows condensation to form and will cause your unit to rust.

**IMPORTANT:** Never cover trimmer while engine and exhaust areas are still warm.

**CAUTION:** Never store the trimmer with gasoline in the tank inside a building where fumes may reach an open flame or spark. Allow the engine to cool before storing in any enclosure.



**TROUBLESHOOTING - See appropriate section in manual unless directed to a qualified service center.**

<b>PROBLEM</b>	<b>CAUSE</b>	<b>CORRECTION</b>
<b>Does not start</b>	<ol style="list-style-type: none"> <li>1. Dirty air filter.</li> <li>2. Out of fuel.</li> <li>3. Stale fuel.</li> <li>4. Water in fuel.</li> <li>5. Spark plug wire is disconnected.</li> <li>6. Bad spark plug.</li> <li>7. Throttle control lever not in correct position (if equipped).</li> </ol>	<ol style="list-style-type: none"> <li>1. Clean/replace air filter.</li> <li>2. Fill fuel tank.</li> <li>3. Empty fuel tank and refill with fresh, clean gasoline.</li> <li>4. Empty fuel tank and refill with fresh, clean gasoline.</li> <li>5. Connect wire to spark plug.</li> <li>6. Replace spark plug.</li> <li>7. Move throttle lever to FAST position.</li> </ol>
<b>Loss of power</b>	<ol style="list-style-type: none"> <li>1. Dirty air filter.</li> <li>2. Buildup of grass, leaves, and trash under trimmer.</li> <li>3. Too much oil in engine.</li> <li>4. Walking speed too fast.</li> </ol>	<ol style="list-style-type: none"> <li>1. Clean/replace air filter.</li> <li>2. Clean underside of trimmer and trimmer head.</li> <li>3. Check oil level.</li> <li>4. Trim at slower walking speed.</li> </ol>
<b>Excessive Vibration</b>	<ol style="list-style-type: none"> <li>1. Lines uneven or broken.</li> <li>2. Loose nuts or bolts.</li> <li>3. Damaged trimmer head.</li> </ol>	<ol style="list-style-type: none"> <li>1. Check trimmer lines.</li> <li>2. Check all hardware, including engine bolts.</li> <li>3. Check/repair trimmer head.</li> </ol>
<b>Starter rope hard to pull</b>	<ol style="list-style-type: none"> <li>1. Bent engine crankshaft.</li> </ol>	<ol style="list-style-type: none"> <li>1. Contact a qualified service center.</li> </ol>
<b>Loss of head drive</b>	<ol style="list-style-type: none"> <li>1. Belt not driving.</li> </ol>	<ol style="list-style-type: none"> <li>1. Put belt on pulleys or replace belt if broken.</li> </ol>
<b>Hard to push</b>	<ol style="list-style-type: none"> <li>1. Handle height position not right for you.</li> </ol>	<ol style="list-style-type: none"> <li>1. Adjust handle height to suit.</li> </ol>
<b>Poor trimming performance</b>	<ol style="list-style-type: none"> <li>1. Trimmer line length is too short.</li> <li>2. Throttle control lever not in correct position (if equipped).</li> </ol>	<ol style="list-style-type: none"> <li>1. If line is worn or broken to half of original length, replace line.</li> <li>2. Move throttle lever to FAST position.</li> </ol>
<b>Trimmer head does not retain line</b>	<ol style="list-style-type: none"> <li>1. Trimmer line not properly installed.</li> <li>2. Broken line retainer clip.</li> <li>3. Incorrect size of trimmer line.</li> </ol>	<ol style="list-style-type: none"> <li>1. Follow instructions in Maintenance section.</li> <li>2. Replace string carrier plate assembly.</li> <li>3. Use correct diameter trimmer line.</li> </ol>

# SERVICE NOTES

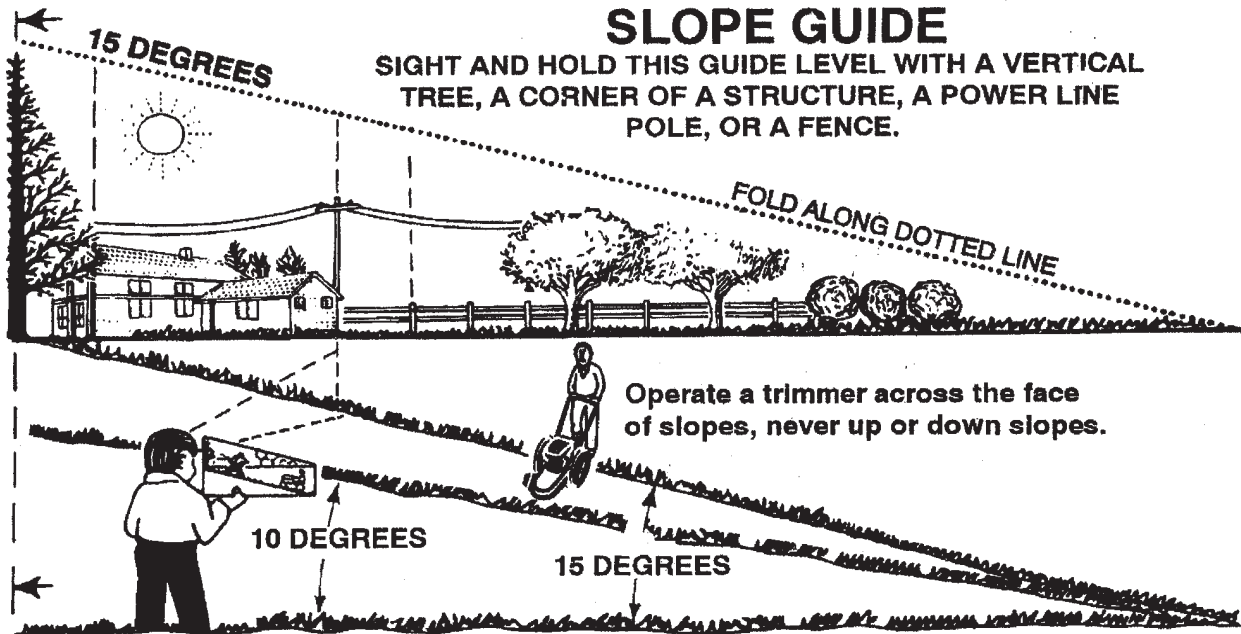

Use this guide and do not trim on a slope greater than 15 degrees.

A 10 degree slope is a hill that increases in height at approximately 1.7 feet in 10 feet.

A 15 degree slope is a hill that increases in height at approximately 2.5 feet in 10 feet.

Use extreme care at all times and avoid sudden turns or maneuvers. Follow other instructions in this manual for safety in trimming on slopes. Operate a trimmer across the face of slopes, never up or down slopes. Use extra care when operating on or near slopes and obstructions.



**WHEELED WEEDTRIMMER**